

ERHARD is a company of



Data sheet  
ERHARD TWIN-AIR®  
air valves



# ERHARD TWIN-AIR® air valves

## **The valve for automatic air release and air admission of pipelines**

Thanks to its large cross-section and the very high ventilation speeds, the ERHARD TWIN-AIR air valve is ideal for use in larger pipe networks and guarantees safe pipe ventilation during the filling process, operational air release being in service and during the draining process. Notwithstanding the high performance, the construction is compact and space-saving.

The ERHARD TWIN-AIR Air Valve has two nozzles. Air can first escape via both orifices in the pipe filling process which means high ventilation performance. Both orifices will be shut once the water level has reached the floating point of the balls. If air should however accumulate during ongoing operation, only the float ball of the small orifice will drop thus releasing the small valve until the air volume has escaped. The small orifice is being purged by a cleaning device with every switching action.



### **Operating instruction**

BA69E010\_TWIN\_AIR\_  
DN50-200



# The overview

## Brief specifications:

- Body and body cover made of ductile cast iron EN-JS 1050
- Body inside: vitreous enamel
- Body outside: EKB fusion bonded epoxy
- Body cover: inside and outside EKB fusion bonded epoxy
- Float ball for DN 50 to DN 100 made of multichamber GRP (optional of austenitic CrNi steel 1.4571)
- Float ball for DN 150 and DN 200 made of austenitic CrNi steel (1.4571)
- Float guide and float assembly for evacuation under pressure made of austenitic CrNi steel (1.4571)
- Body seat made of EPDM, W270
- Connecting bolts made of stainless steel A4



## Range of application

- Automatic air release and air admission of pipelines for potable water
- Special designs on request, e. g. with protective screen, with surge check valve, with air lock, etc.

## Operating conditions

- Minimum working pressure: 0.2 bar
- Maximum working pressure: up to 40 bars
- Maximum working temperature: 60 °C

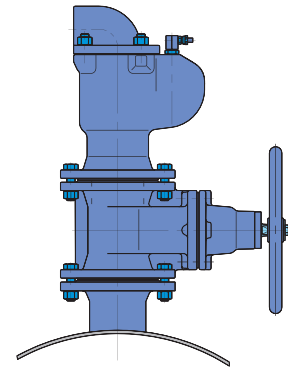

## Dimensions and weights

DN	Height H (mm)	Flange-Ø D				External dim. L x B (mm)	Orifice cross section mm <sup>2</sup>			Threaded connection A	Weight kg	Volume m <sup>3</sup>
		PN10	PN16	PN25	PN40		large orifice	small orifice				
								PN10-25	PN40			
50	317	165	165	165	165	240 x 191	3850	5	1.75	G 2 1/2	19	0,015
80	317	200	200	200	200	240 x 191	3850	5	1.75	G 2 1/2	19	0,015
100	333	220	220	235	235	240 x 191	3850	5	1.75	G 2 1/2	20	0,015
150	385	285	285	300	300	316 x 222	9500	5	1.75	G 4	32	0,029
200	385	340	340	360	375	316 x 222	9500	5	1.75	G 4	43	0,029

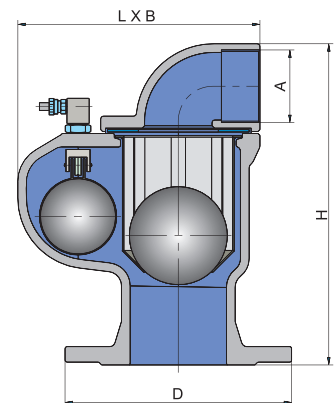

## Pressure ratings and flanges

Nominal size DN	Pressure rating PN	Hydrost. test pressure in bars for (DIN EN 12266)		Design dimensions of the flanges
		Body Water	Seat Water	
50-200	25	37,5	0,2/25	Flange B, DN 50 - 200, PN 25, EN 1092-2
50-200	40	60,0	0,2/40	Flange B, DN 50 - 200, PN 40, EN 1092-2
100-200	16	25,0	0,2/16	Flange B, DN 100 - 200, PN 16, EN 1092-2
200	10	15,0	0,2/10	Flange B, DN 200, PN 10, EN 1092-2

# Air outflow and inflow capacities

The suitable valve size is selected on the basis of the actual working conditions.

## Air capacity

For air capacities, see diagrams on the right:

1. Air evacuation via the large orifice (filling the pipeline). The air flow rate  $Q$  is identical with the inflowing water rate.
2. Air evacuation via the small orifice (under working pressure).
3. Air admission via the large orifice (emptying the pipeline). The air flow rate  $Q$  is identical with the outflowing water rate.

## Extreme air rate demand

If one single air valve cannot comply with the specified outflow and inflow requirements, air valves can be fitted in clusters. For large air inflow rates (valves larger than DN 200), ERHARD Disc Type Air Inlet Valves are the appropriate solution.

## Recommended limit values

### Filling the pipeline

During the closing process of the ERHARD TWIN-AIR Air Valve, for safety reasons the maximum admissible water hammer should not exceed  $P = 3$  bars. This is based on filling the pipeline at a velocity of 0.25 m/sec.

## Recommended limit values

### Emptying the pipeline

The recommended air velocity when emptying the pipeline is  $V_{\max} = 80$  m/sec. (referred to the clear air inflow cross section).